

**SERIE / MODEL** IS □□□  
**CODICE / CODE** 03.01.□□□.01

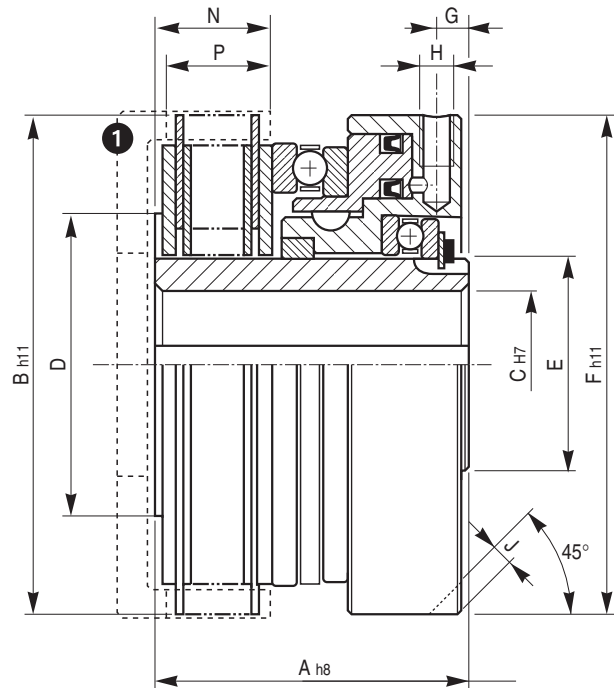
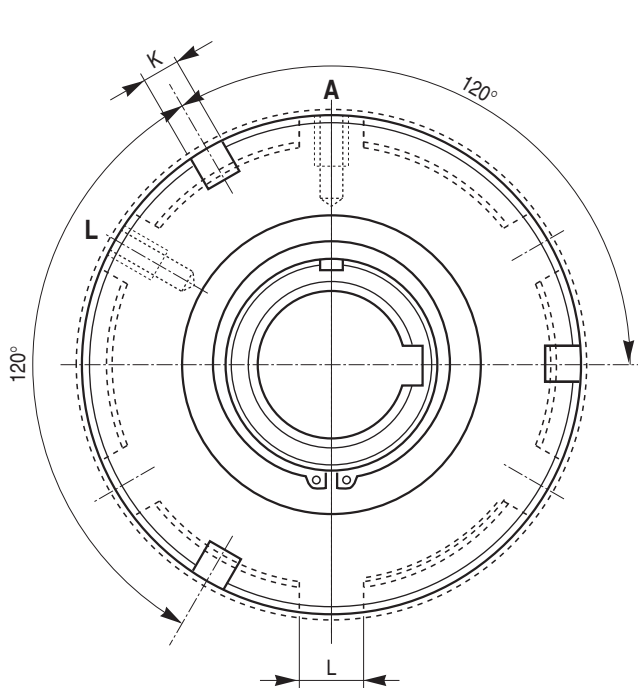

**A** = Alimentazione olio / Oil supply  
**L** = Lubrificazione / Lubrication

□□□	Momenti Torques		Pressione lavoro Working pressure	Volume cilindro Cylinder volume	Peso Weight	Dischi esterni External plates	Campana Cap Housing a richiesta/on demand
	Mi (Nm)	Ms (Nm)	(bar)	(cm <sup>3</sup> )	(kg)	N.	①
<b>025</b>	45	80	8	8	2,5	5	C 03.02
<b>035</b>	65	110	8	10	3,2	5	--
<b>045</b>	100	180	8	11	3,8	6	C 04.01
<b>045/b</b>	125	220	8	12	4,2	6	C 05.01
<b>065</b>	160	280	8	19	7	6	C 06.02
<b>065/b</b>	200	350	8	25	7,5	7	C 06.02
<b>075</b>	300	500	8	40	10,5	8	--
<b>085</b>	400	700	8	46	16	5	C 08.01
<b>105</b>	600	1050	8	86	25	6	C 10.01

□□□	A	B	C		D	E	F	G	H	J	K	L	N	P	Allette Lugs N.
			min	max											
<b>025</b>	69	97	16	30	59	40	98	6	1/8"	4	8	12	24	22	6
<b>035</b>	69	108,5	18	36	72	45	108	7	1/8"	4	8	12,5	25	22	8
<b>045</b>	75	116,5	20	40	72	50	112	6	1/8"	5	8	15	29	25	6
<b>045/b</b>	75	120	20	40	72	50	112	6	1/8"	5	8	16	29	25	8
<b>065</b>	90	145	25	46	92	60	130	7	1/8"	6	10	16	33	30	8
<b>065/b</b>	98	145	25	48	92	60	138	7	1/8"	6	10	16	36	32	8
<b>075</b>	105	145	30	44	92	55	158	8	1/4"	7	10	16	41	37	8
<b>085</b>	115	179	30	58	70	75	180	25	1/4"	8	10	20	35	26	9
<b>105</b>	165	218	30	58	70	75	235	24	1/4"	10	12	20	43	34	10