

PPHP-N310/□□□

Pneumatico Negativo / Pneumatically Released

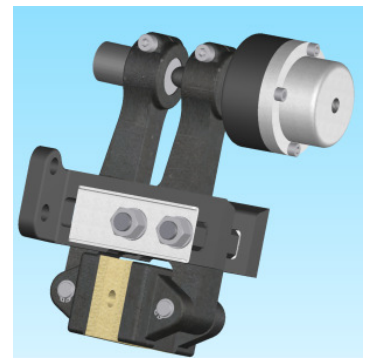
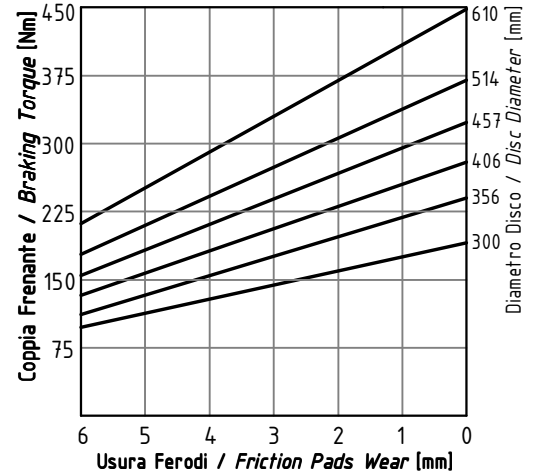
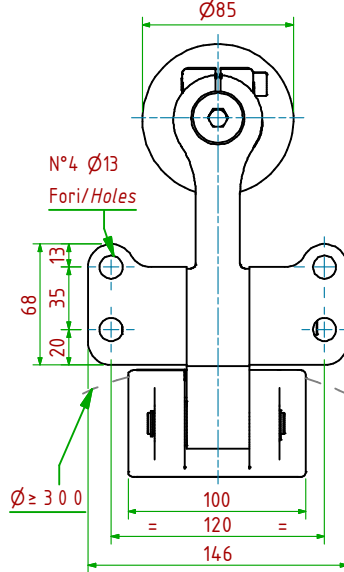
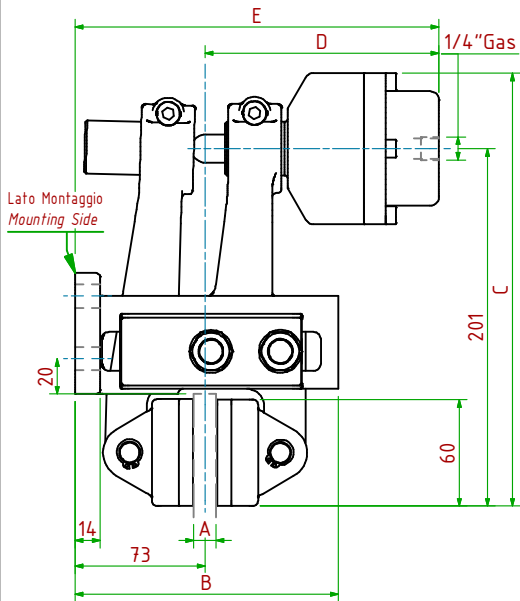

- Pressione di Apertura/Release Pressure: **Pa= 6bar** - Volume Max Cilindro/Max Cylinder Volume: **32cm³**
- Coppia Frenante/Braking Torque: **Md= [Ftx(Φ(m)/2-0.033(m))]**
- Importante:** La Coppia Frenante Iniziale può essere più bassa del 30%-50% **Warning:** Initial Braking Torque can be lower of 30%-50%
- Usura Ferodi Massima Totale/Maximum total wear of pads =9mm

| MODELLO / MODEL | CODICE / CODE | A | B | C | D _{Max} | E _{Max} | Forza Frenante/Braking Force | Peso |
|-----------------|---------------|------|-----|-----|------------------|------------------|------------------------------|--------|
| PPHP-N310/12.7 | 19.36.310.03 | 12.7 | 148 | 244 | 131 | 204 | Ft= 1650N (0bar) | 9.5 kg |
| PPHP-N310/25.4 | 19.36.310.04 | 25.4 | 148 | 244 | 137 | 210 | Ft= 1650N (0bar) | 9.7 kg |

PPHP-N320/□□□

Pneumatico Negativo / Pneumatically Released

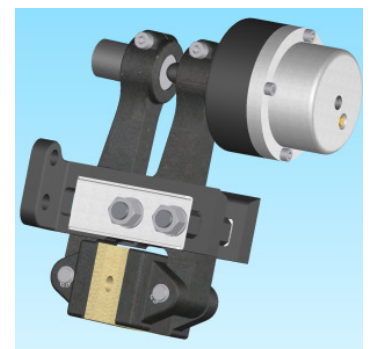
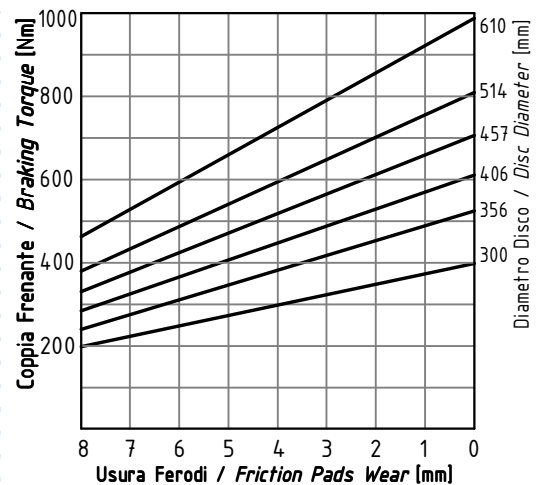
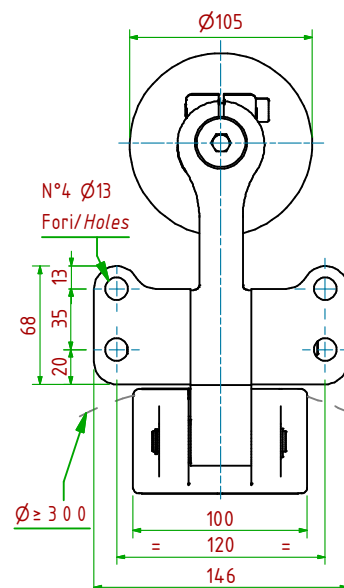
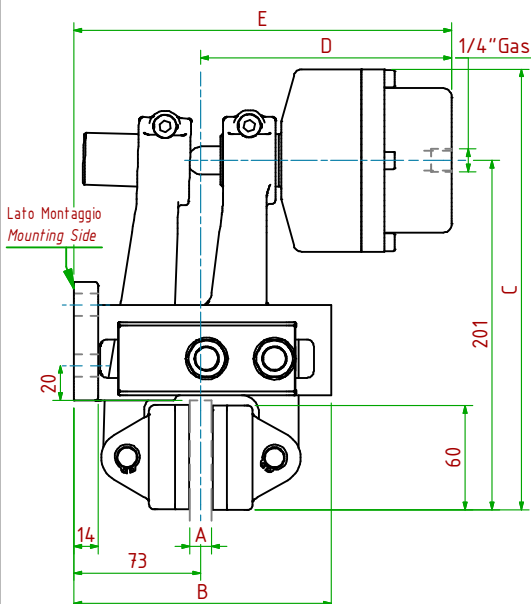

- Pressione di Apertura/Release Pressure: **Pa= 6bar** - Volume Max Cilindro/Max Cylinder Volume: **75cm³**
- Coppia Frenante/Braking Torque: **Md= [Ftx(Φ(m)/2-0.033(m))]**
- Importante:** La Coppia Frenante Iniziale può essere più bassa del 30%-50% **Warning:** Initial Braking Torque can be lower of 30%-50%
- Usura Ferodi Massima Totale/Maximum total wear of pads =9mm

| MODELLO / MODEL | CODICE / CODE | A | B | C | D _{Max} | E _{Max} | Forza Frenante/Braking Force | Peso |
|-----------------|---------------|------|-----|-----|------------------|------------------|------------------------------|--------|
| PPHP-N320/12.7 | 19.36.320.03 | 12.7 | 148 | 254 | 144 | 217 | Ft= 3400N (0bar) | 10.5kg |
| PPHP-N320/25.4 | 19.36.320.04 | 25.4 | 148 | 254 | 150 | 223 | Ft= 3400N (0bar) | 10.7kg |