

PPHP-PN330/□□□

Pneumatico DUO / Pneumatically DUO

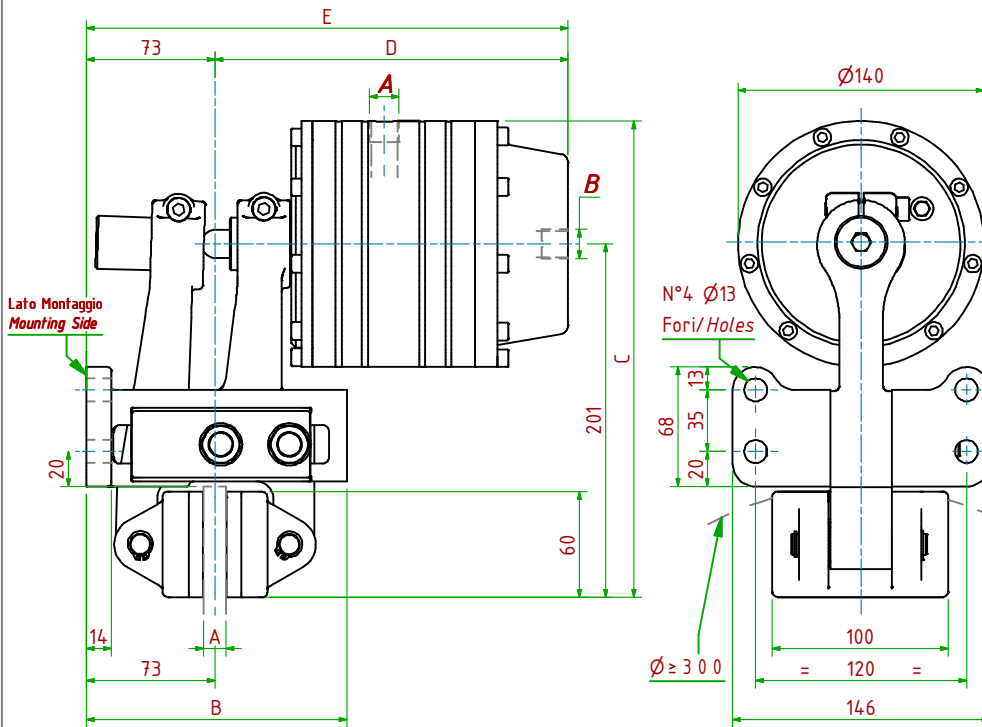

Funzionamento Positivo/Pneumatically Applied

- Pressione di Lavoro/Operating Pressure **Pl= 6bar**
- Alimentazione Cilindro/Pneumatic Cylinder Supply **A: 3/8"Gas**
- Volume Max Cilindro/Max Cylinder Volume **110 cm³**
- Coppia Frenante/Braking Torque **Md= [Ftx(Φ(m)/2-0.029(m))]**

Funzionamento Negativo/Pneumatically Released

- Pressione di Apertura/Release Pressure **Pa= 6bar**
- Alimentazione Cilindro/Spring Applied Cylinder Supply **B: 3/8"Gas**
- Volume Max Cilindro/Max Cylinder Volume **160 cm³**
- Usura Ferodi Massima Totale/Maximum total wear of pads =9mm

MODELLO/MODEL	CODICE/ CODE	A	B	C	DMax	EMax	Forza Frenante: Positivo-Negativo / Braking Force	Peso
PPHP-PN330/12.7	19.56.330.03	12.7	148	271	201	274	Ft _{pos} = 8020N (6bar) Ft _{neg} = 6800N (0bar)	13.4 kg
PPHP-PN330/25.4	19.56.330.04	25.4	148	271	207	280	Ft _{pos} = 8020N (6bar) Ft _{neg} = 6800N (0bar)	13.5 kg

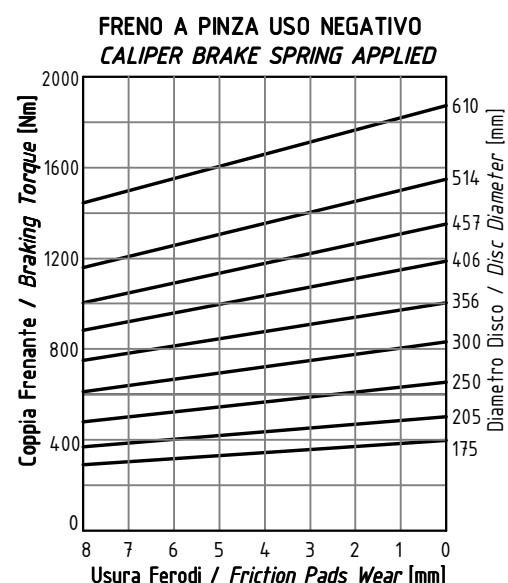
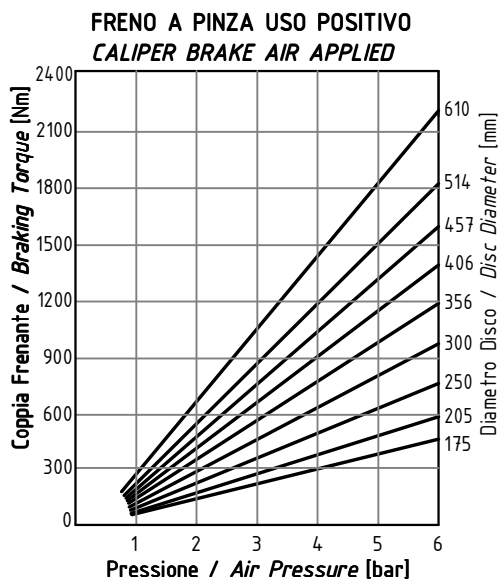

Coppia Frenante Md

La coppia frenante iniziale può essere dal 30% al 50% in meno rispetto al valore nominale, fino al completo assestamento del ferodo sulla superficie del disco.

Braking Torque Md

The initial braking torque can be from 30% up to 50% less than nominal torque, until the friction pad works correctly on the disc surface.