

SERIE/MODEL
CODICE/CODE

①	GFF □□□/A-A/P
	09.01.□□□.11

②	GFF □□□/A-A/P
	09.01.□□□.12

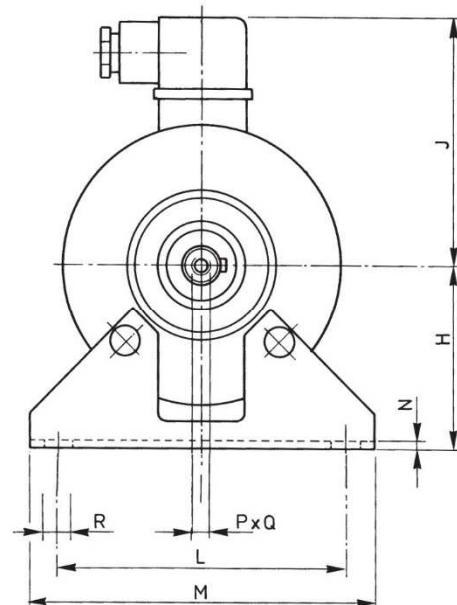
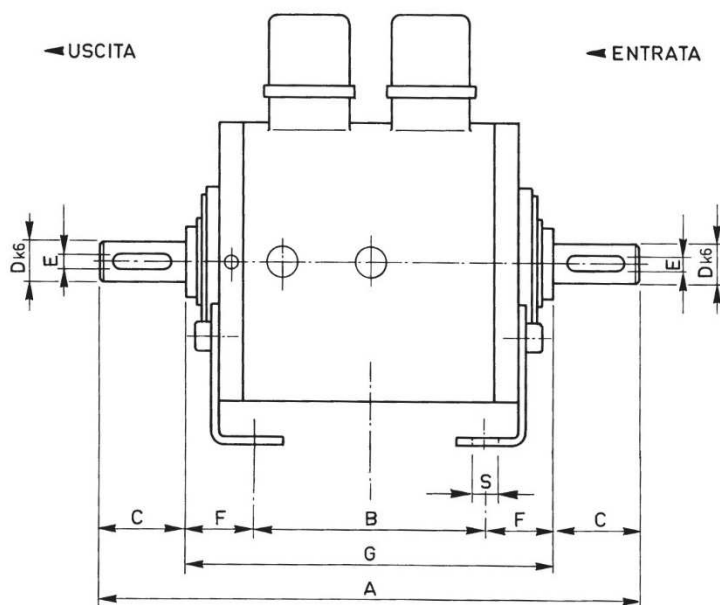

□□□		Momenti Torques		Giri/1' R.P.M. limit Max.	Tempi inser. Build up time ms	Tempi disin. Decay time ms	Watt		Peso Weight Kg
		Mi (Nm)	Ms (Nm)				20°	120°	
060	Frizione/Clutch	6	7,5	8000	48	14	16	11,5	3,5
	Freno/Brake				40	9	12	8,6	
080	Frizione/Clutch	12	15	6000	78	16	22	15,8	5,8
	Freno/Brake				50	10	17	12,2	
100	Frizione/Clutch	24	30	5000	125	30	30	21,6	8,9
	Freno/Brake				70	14	22	15,8	
130	Frizione/Clutch	50	70	4000	160	45	38	27,3	14,5
	Freno/Brake				100	18	30	21,6	
170	Frizione/Clutch	95	130	3000	200	55	52	37,4	20,5
	Freno/Brake				150	25	40	28,8	

□□□	□□	A	B	C	D	E	F	G	H	J	K	L	M	N	PxQ	R	S
060	.11	174	80	23	11	4	24	128	63	90	7	100	120	2,5	M5x10	11	7
	.12	188		30	14	5											
080	.11	205	90	30	14	5	27,5	145	71	100	7	112	136	3	M6x12	11	7
	.12	225		40	19	6											
100	.11	243	100	40	19	6	31,5	163	90	115	9	140	170	3,5	M8x15	13	9
	.12	263		50	24	8											
130	.11	308	140	50	24	8	34	208	100	130	12	160	190	3,5	M8x15	16	12
	.12	328		60	28	8											
170	.11	346	140	60	28	8	43	226	132	150	12	216	256	5	M10x20	16	12
	.12	386		80	38	10											