

SERIE/MODEL

ESB □□□/S

CODICE/CODE

05.05.□□□.01

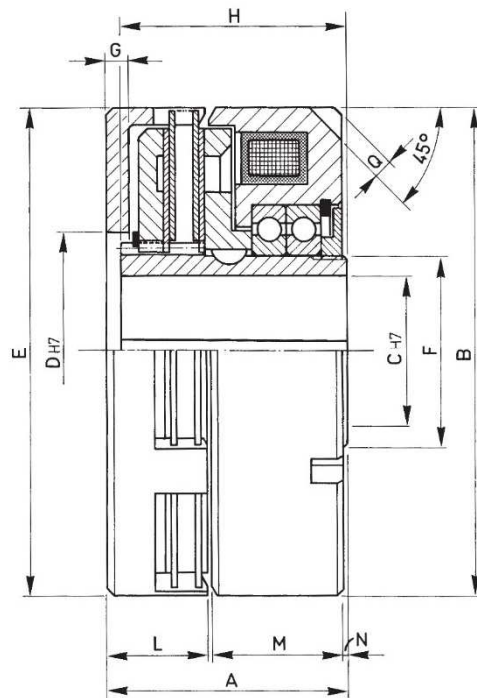
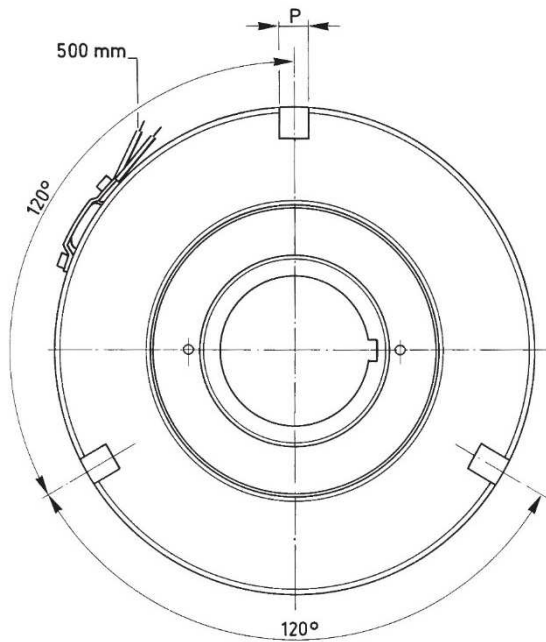

□□□	Momenti Torques		Giri/1' R.P.M. Max	Tempi inser. Build up time ms	Tempi disin. Decay time ms	WATT		Peso Weight Kg	Dischi esterni External plates N.
	Mi (Nm)	Ms (Nm)				20 °C	120 °C		
070	6	10	500	110	40	23	16	1,20	3
082	12	22	475	160	50	34	24	1,60	3
092	25	45	440	210	65	40	29	2,20	4
114	60	100	350	270	100	48	34	3,60	4
134	120	200	250	350	110	66	48	5,80	4
140	150	250	180	380	120	72	52	6,50	5
166	240	400	120	440	195	86	62	9,50	4
167	360	600	80	520	215	115	83	9,30	6
195	480	800	70	600	240	102	73	15,20	5
210	720	1100	50	740	290	130	94	19	5
240	1200	1800	40	890	370	150	108	27	6
260	1500	2400	30	1080	390	160	115	30	7
295	2000	3200	25	1250	520	230	166	48	7

□□□	A	B	C		D	E	F	G	H	L	M	N	P	Q
			Min	Max										
070	38,5	70	10	14	24	70	20	4	34,5	14,5	22,5	0,5	6	3,5
082	51	83	12	20	30	83	25	5	46,5	19	30	1	6	4
092	56	95	15	30	45	92	37	5	52	20	34	1	6	5
114	63	114	18	34	50	114	40	6	58,5	25	36	1,5	8	4,5
134	73	134	20	42	60	134	50	6	68	29	42	1	8	5
140	76	140	20	46	65	140	55	7	70	32	42	1	8	6
166	82,5	166	25	52	70	166	60	8	76	34	45	1,5	10	6
167	91	166	30	55	60	166	70	7,5	84	39	50	1	10	6
195	94,5	195	30	65	70	195	80	9	83,5	43	49	1,5	12	8
210	103	210	35	70	75	210	85	10	91	46	54	2	12	8
240	110,5	240	35	80	90	240	95	10	98	50	56	2	12	10
260	112	258	40	100	120	258	120	10	99,5	52	56	2	12	10
295	131	295	50	110	140	295	140	11	117	64	62	2	14	12