

SERIE/MODEL	RT5A
CODICE/COE	51.06.RT5A

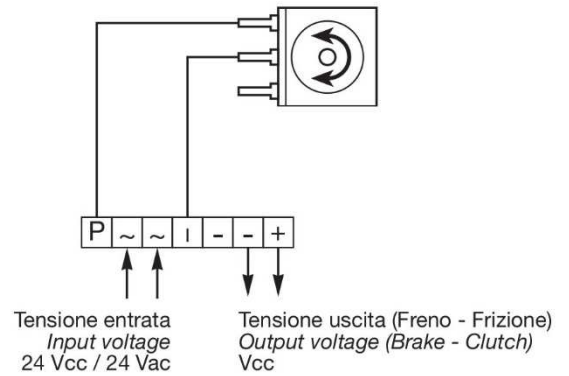

Tensione uscita
Output voltage
Vcc

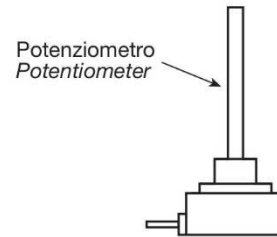
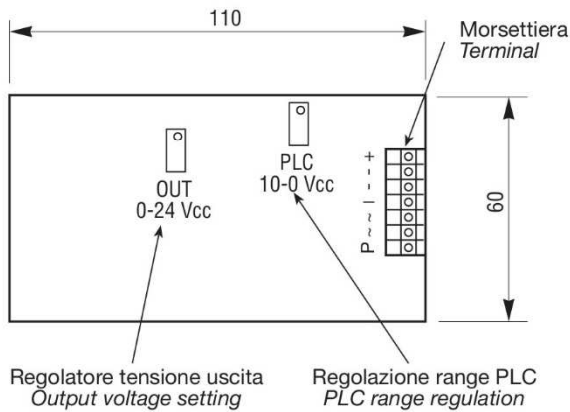
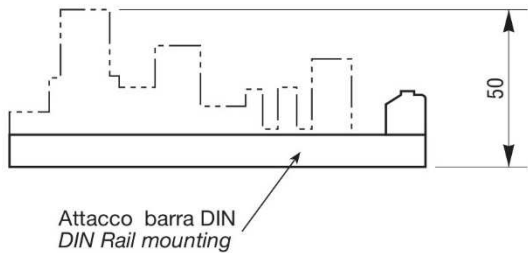
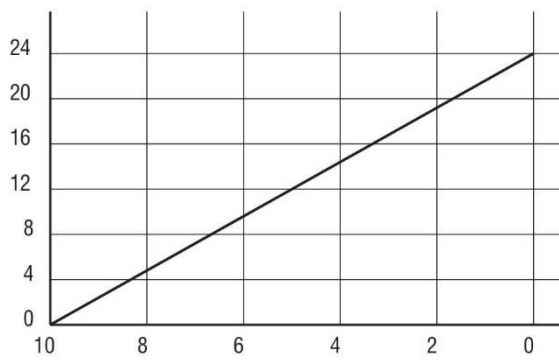

Regolazione range PLC
PLC range regulation
Vcc

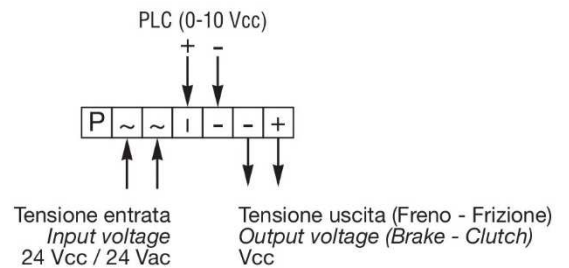

Tramite la regolazione del Potenziometro o del PLC, si può variare la tensione di uscita, vedi diagramma.

We can change output voltage setting potentiometer or PLC, see diagram.

ALIMENTATORE 0-24Vcc / 70W

POWER SUPPLY 0-24VDC / 70W

Tensione di Ingresso: 24Vac / 24Vcc

Input voltage: 24Vac / 24VDC

Tensione di Uscita: 0-24Vcc (Regolabile)

Output voltage: 0-24Vcc (Adjustable)

Regolatore della tensione in uscita: - POTENZIOMETRO
- PLC (da 10 a 0Vcc)

Output voltage setting: - POTENTIOMETER
- PLC (from 10 to 0VDC)

Corrente in uscita: 3A continuativi / 5A Picco

Output current: 3A working / 5A Peak

Attacco Barra DIN

DIN Rail mounting