

POD011/

Oleodinamico / Hydraulically Applied

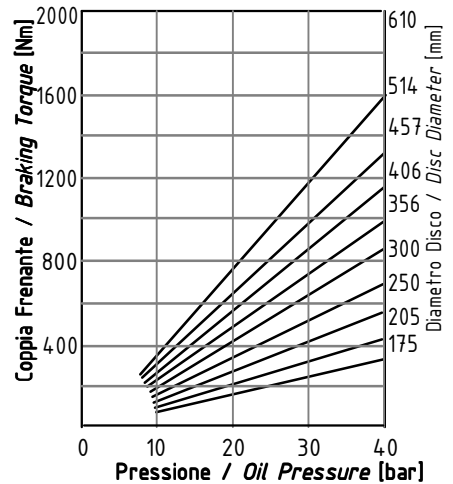
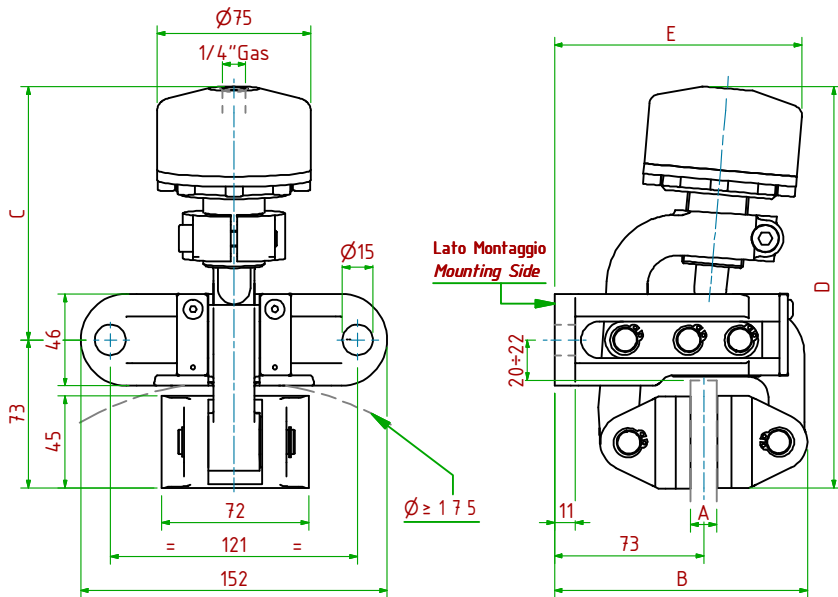

- Pressione di Lavoro/Operating Pressure: **Pl=50bar** - Volume Max Cilindro/Max Cylinder Volume: **27cm³**
- Coppia Frenante/Braking Torque **Md=[Ft×(ø(m))/2-0.029(m)]**
- Importante:** La Coppia Frenante Iniziale può essere più bassa del 30%-50% **Warning:** Initial Braking Torque can be lower of 30%-50%
- Usura Ferodi Massima Totale/Maximum total wear of pads =9mm

MODELLO/ MODEL	CODICE/ CODE	A	B	C	D _{Max}	E _{Max}	Forza Frenante/Braking Force	Peso
POD011/12.7	19.26.011.03	12.7	124	127	200	125	Ft= 5800N (40bar)	4.5 kg
POD011/25.4	19.26.011.04	25.4	130	127	200	127	Ft= 5800N (40bar)	4.7 kg

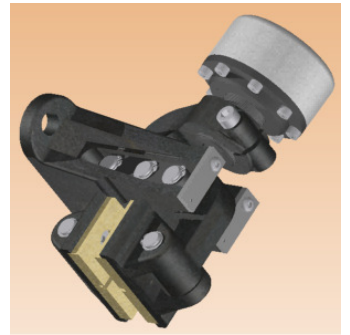

POF021/

Oleodinamico / Hydraulically Applied

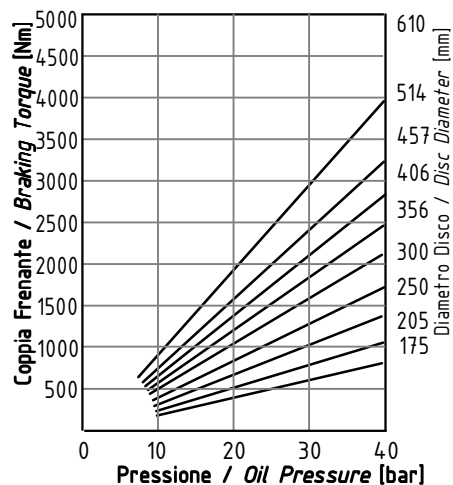
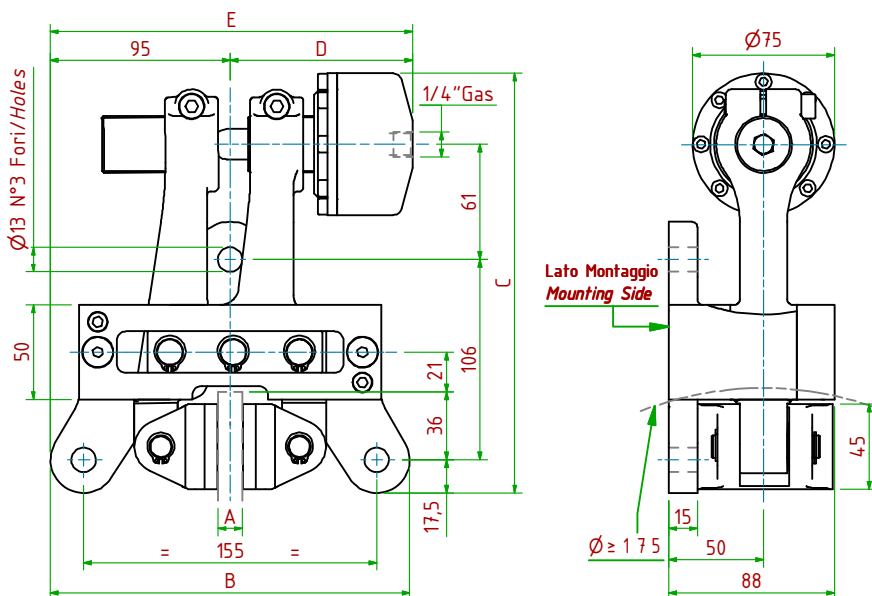

- Pressione di Lavoro/Operating Pressure: **Pl=50bar** - Volume Max Cilindro/Max Cylinder Volume: **27cm³**
- Coppia Frenante/Braking Torque **Md=[Ft×(ø(m))/2-0.029(m)]**
- Importante:** La Coppia Frenante Iniziale può essere più bassa del 30%-50% **Warning:** Initial Braking Torque can be lower of 30%-50%
- Usura Ferodi Massima Totale/Maximum total wear of pads =9mm

MODELLO/ MODEL	CODICE/ CODE	A	B	C	D _{Max}	E _{Max}	Forza Frenante/Braking Force	Peso
POF021/12.7	19.26.021.03	12.7	190	222	97	192	Ft= 14150N (40bar)	8.2 kg
POF021/25.4	19.26.021.04	25.4	190	222	99	194	Ft= 14150N (40bar)	8.4 kg

